

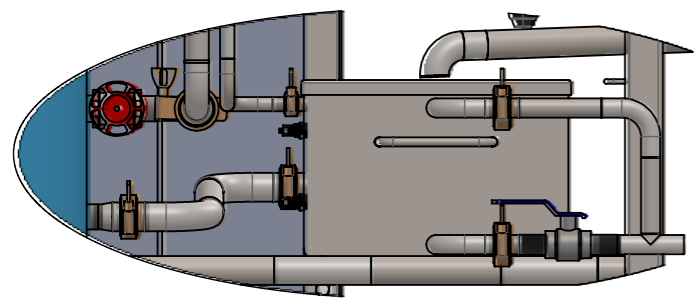

© STYNE Ltd. THIS PRINT IS SUPPLIED IN CONFIDENCE AND MUST NOT BE LOANED, COPIED OR REPRODUCED WITHOUT WRITTEN PERMISSION

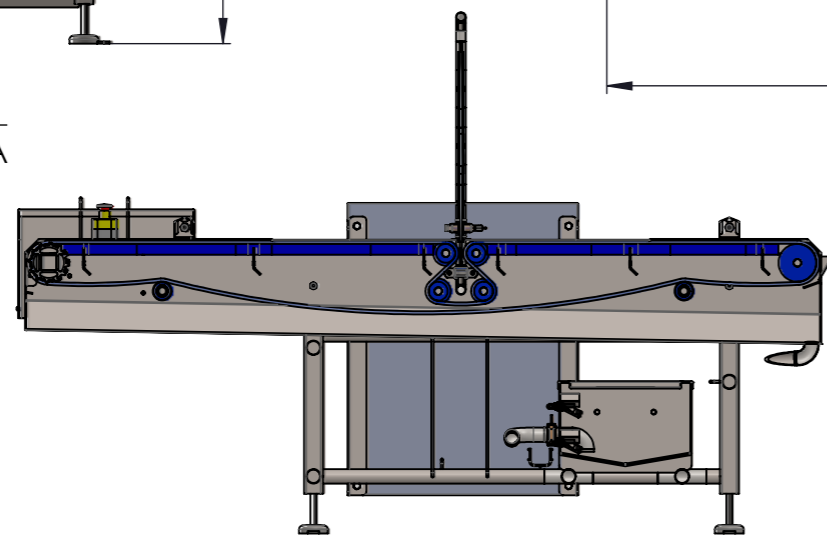

DETAIL B
SCALE 1 : 10

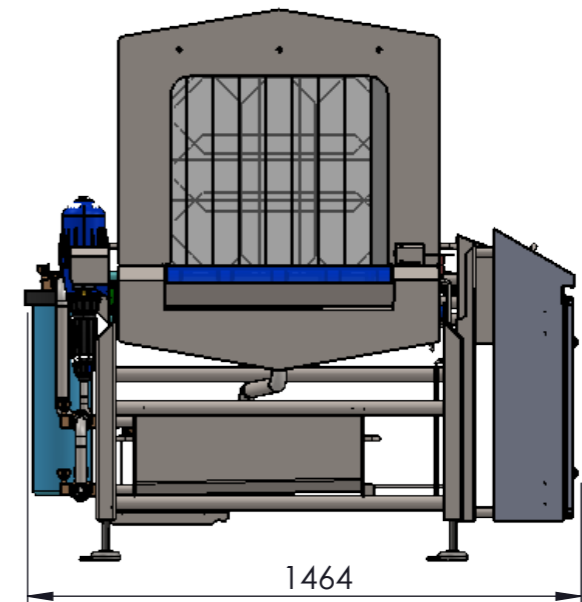
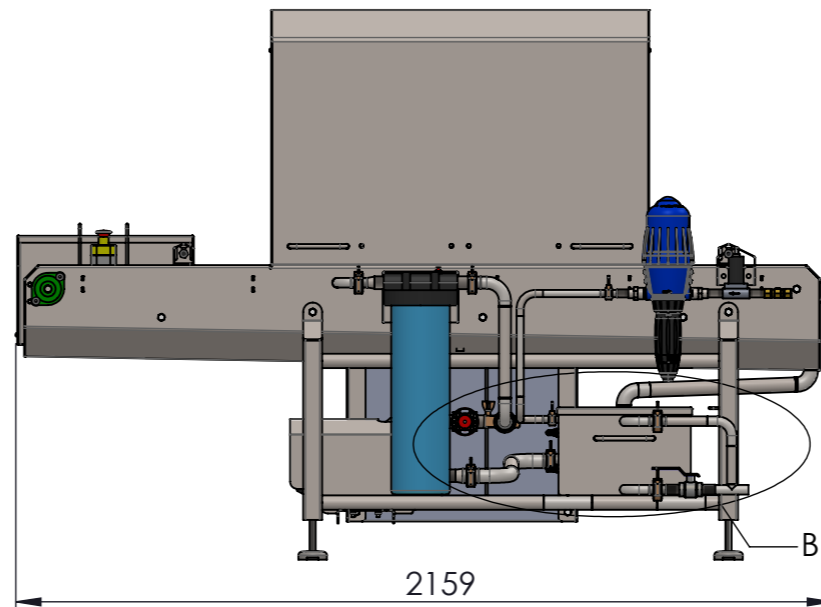
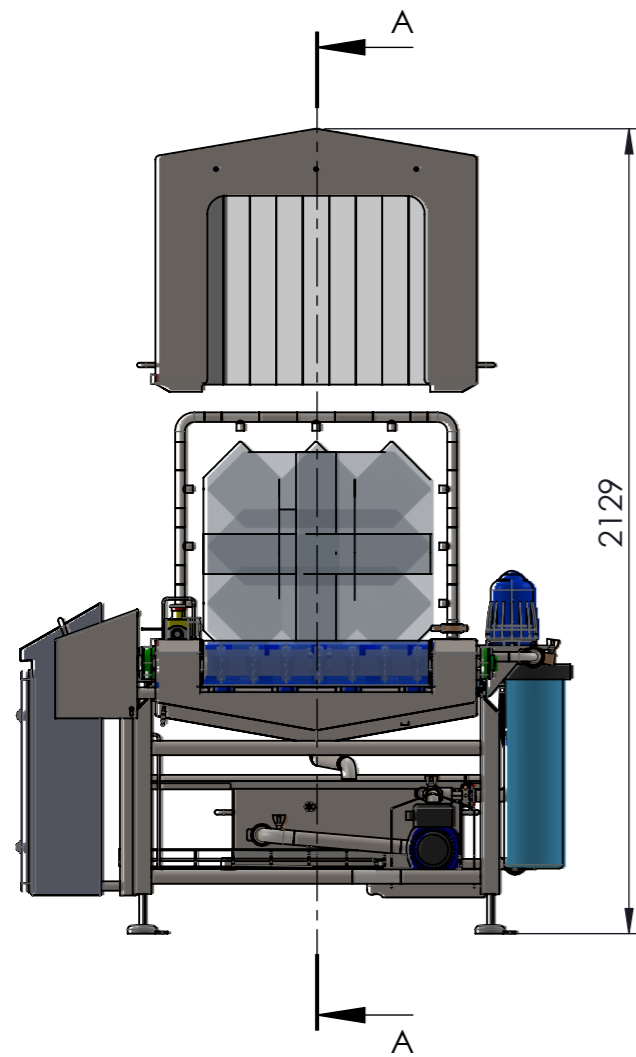
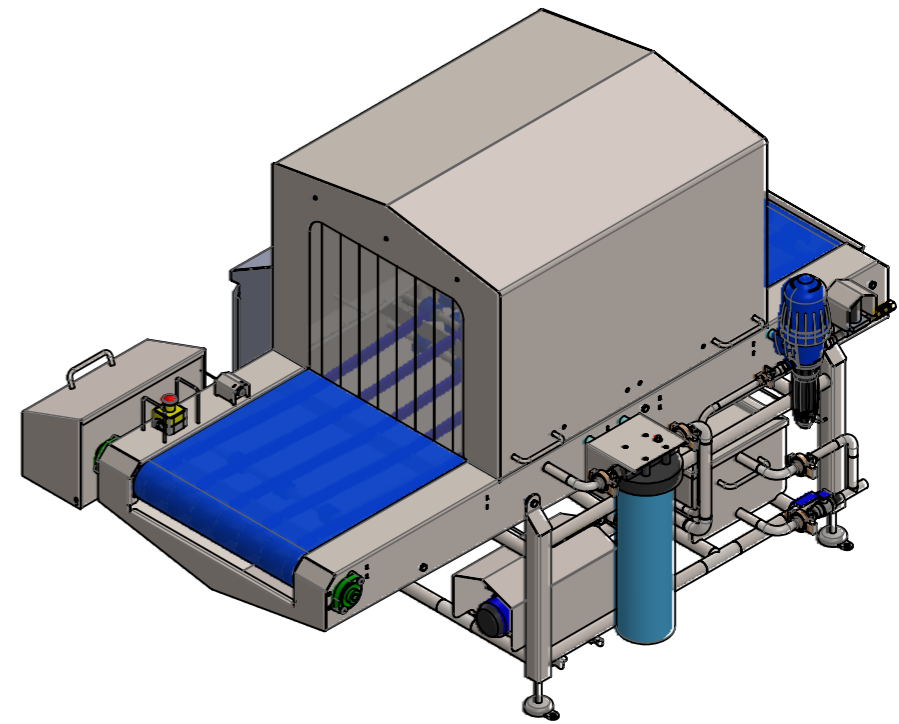
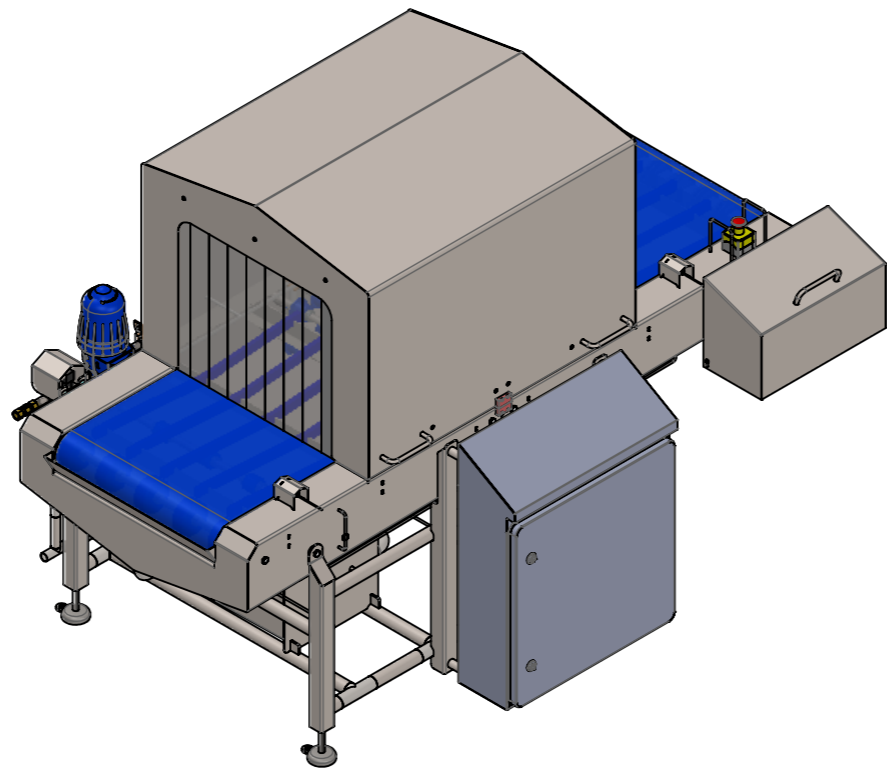

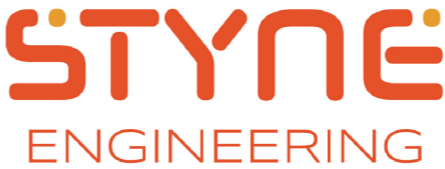
SECTION A-A

REV.	DESCRIPTION	DATE	DRAWN	APPROVED
				
<p>NOTES: 1. ALL DIMENSIONS ARE TAKEN TO SHARP CORNERS. 2. REMOVE SHARP EDGES.</p>				
PURCHASED:		VENDOR:		GENERAL TOLERANCES: Machining to ISO 2768 m, K Fabrication to ISO 13920 Class A ALL DIMENSIONS IN mm IF IN DOUBT ASK
MATERIAL: SEE PARTS LIST		PART N°:		
WEIGHT: 325.07kg		FINISH:		
JOB N°:		QUANTITY:		
CUSTOMER:			SCALE: 1:20	
DESCRIPTION:			A3	
DRAWING N°: A17156 - sanitiser assembly rev E			DRAWN BY:	SHEET: 1 of 1
			DRAWN DATE: 11/03/2021	REV: 00

STYNE LTD
FALCON HALL
RICKINGHALL
DISS
NORFOLK
IP22 1LP

TEL: 01379 897120
www.styne.co.uk
info@styne.co.uk